

SunX

Compact Multi-voltage Photoelectric Sensor

MS-AJ

Sensor Mounting Stand

PM

Micro

PM2

NX5

Multi-voltage Type

VF

SU-7/SH

SS-A5

CHX-SC2

Sensor Checker



Multi-voltage Photoelectric Sensor Usable Worldwide

CE Marked
Conforming to Low Voltage and EMC Directives

Multi-voltage

The **NX5** series can operate at 24 to 240V AC or 12 to 240V DC, which makes it suitable for supply voltages all over the world.

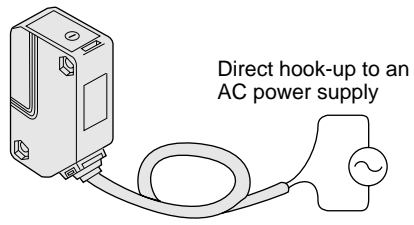

No need to arrange a DC power supply.

Long Sensing Range

Most suitable for conveyor lines and parking lot applications.

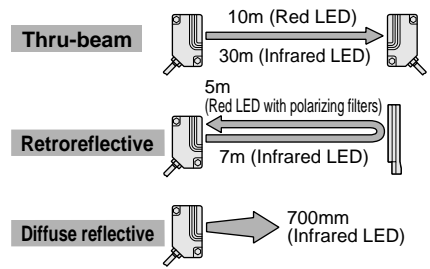

High Reliability

It has IP66 protection. Moderate dust or water splashes do not affect it. The new N₂ hermetically sealed output relay significantly increases its reliability.

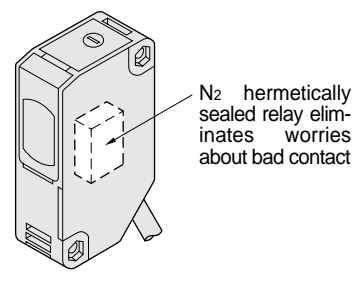

Compact Size

Despite being multi-voltage, it has a depth of just 35mm. (W18 × H62 × D35mm)

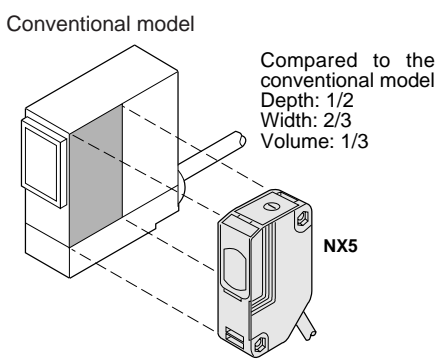

Easy Alignment

The 10m thru-beam type sensor and the 5m retroreflective type sensor incorporate a red LED beam source. Beam alignment can be attained by visually checking the emitted beam.

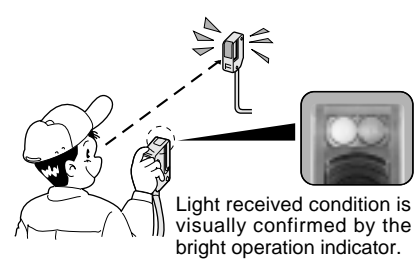

Interference Prevention

Two sensors operate quite normally even if mounted closely. (Excluding the 30m thru-beam type sensor)

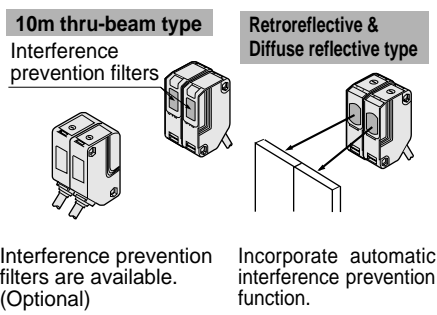

APPLICATIONS

Detecting car position at parking garage

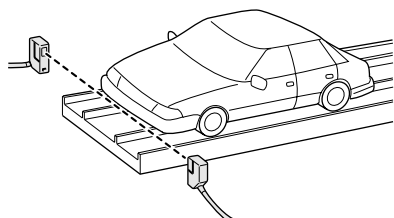

Detecting workpieces on conveyor line

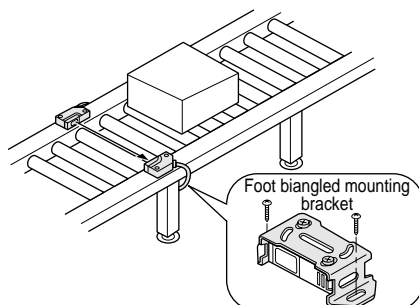

Detecting golf balls

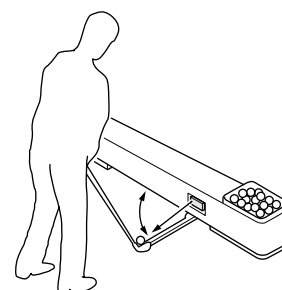

ORDER GUIDE

Type	Appearance	Sensing range	Model No. (Note 2)	Emitting element
Thru-beam		10m	NX5-M10RA	Red LED
			NX5-M10RB	
		30m	NX5-M30A	Infrared LED
			NX5-M30B	
Retroreflective		0.1 to 5m (Note 1)	NX5-PRVM5A	Red LED
			NX5-PRVM5B	
		0.1 to 7m (Note 1)	NX5-RM7A	Infrared LED
			NX5-RM7B	
Diffuse reflective		700mm	NX5-D700A	Infrared LED
			NX5-D700B	

NOTE: Mounting bracket is not supplied with the sensor. Please select from the range of optional sensor mounting brackets (three types).

Notes: 1) The sensing range of the retroreflective type sensor is specified for the RF-230 reflector. Further, the sensing range is the possible setting range for the reflector. The sensor can detect an object less than 0.1m away.

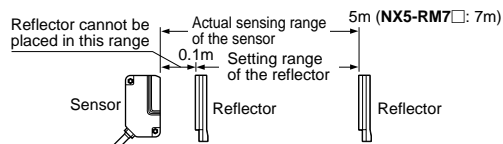

2) Light-ON type sensor (model No. with suffix 'A') and Dark-ON type sensor (model No. with suffix 'B') are available in the NX5 series. For the following models, in case of power off, the output relay condition is the same as when an object is detected. (In case of power supply line disconnection, the output operation is the same as when an object is detected.) Refer to P.336 for the output operation of each model.

Thru-beam type	Retroreflective type	Diffuse reflective type
NX5-M10RA and NX5-M30A (Light-ON)	NX5-PRVM5A and NX5-RM7A (Light-ON)	NX5-D700B (Dark-ON)

5m cable length type

5m cable length models are available (Standard: 2m). When ordering this type, add suffix '-C5' to the model No. (e.g.) 5m cable length type of NX5-M10RA is 'NX5-M10RA-C5'.

Sensor Mounting Stand
MS-AJ

Micro
PM

PM2

Multi-voltage Type
NX5

VF

Amplifier-separated Type
SU-7/SH

Amplifier-separated Type
SS-A5

Sensor Checker
CHX-SC2

NX5

OPTIONS

Designation	Model No.	Description
Sensor mounting bracket	MS-NX5-1	Foot angled mounting bracket (The thru-beam type sensor needs two brackets.)
	MS-NX5-2	Foot biangled mounting bracket (sensor protection bracket) (The thru-beam type sensor needs two brackets.)
	MS-NX5-3	Back angled mounting bracket (The thru-beam type sensor needs two brackets.)
Slit mask (For thru-beam type sensor only)	OS-NX5-3 X 6 (Slit size 3 X 6mm)	Slit on one side <ul style="list-style-type: none"> • Sensing range: 3m [NX5-M10R□] 16m [NX5-M30□] • Min. sensing object: ϕ10mm
		Slit on both sides <ul style="list-style-type: none"> • Sensing range: 1m [NX5-M10R□] 6m [NX5-M30□] • Min. sensing object: 3 X 6mm
Interference prevention filter (For NX5-M10RA or NX5-M10RB only)	PF-NX5-V (Vertical)	Same type of filters on both sides <ul style="list-style-type: none"> • Sensing range: 5m • Min. sensing object: ϕ20mm (One set consists of 2 Nos. of interference prevention filters.)
	PF-NX5-H (Horizontal)	
Reflector (For retro-reflective type sensor only)	RF-210	<ul style="list-style-type: none"> • Sensing range: 0.1 to 1.5m [NX5-PRVM5□] 0.1 to 2.5m [NX5-RM7□] • Min. sensing object: ϕ30mm
	RF-220	<ul style="list-style-type: none"> • Sensing range: 0.1 to 3.5m [NX5-PRVM5□] 0.1 to 5m [NX5-RM7□] • Min. sensing object: ϕ35mm
Reflector mounting bracket	MS-RF21-1	Protective mounting bracket for RF-210 It protects the reflector from damage and maintains alignment.
	MS-RF22	For RF-220
	MS-RF23	For RF-230
Reflective tape (For retro-reflective type sensor only)	RF-11	<ul style="list-style-type: none"> • Ambient temperature: -25 to +50°C • Ambient humidity: 35 to 85% RH Notes: i) Keep the tape free from stress. If it is pressed too much, its capability may deteriorate. ii) Do not cut the tape. It will deteriorate the sensing performance.
	RF-12	
Sensor checker (Note)	CHX-SC2	It is useful for beam alignment of thru-beam type sensors. The optimum receiver position is given by indicators, as well as, an audio signal.

Note: Refer to P.378~ for details of the sensor checker **CHX-SC2**.

Reflector mounting bracket

- **MS-RF23**
- **MS-RF22**
- **MS-RF21-1**

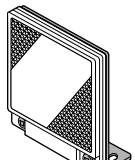

Two M4 (length 10mm) screws with washers are attached.

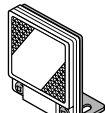

Two M3 (length 8mm) screws with washers are attached.

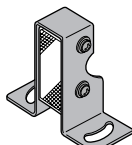

Two M3 (length 12mm) screws with washers are attached.

Sensor mounting bracket

- **MS-NX5-1**
- **MS-NX5-2**
- **MS-NX5-3**

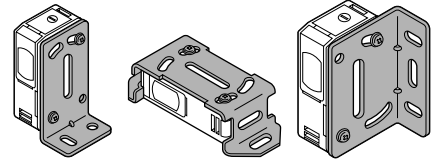

Two M4 (length 25mm) screws with washers and two M4 nuts are attached.

Two M4 (length 25mm) screws with washers and two M4 nuts are attached.

Two M4 (length 25mm) screws with washers and two M4 nuts are attached.

Slit mask

Fitted on the front face of the sensor with one-touch.

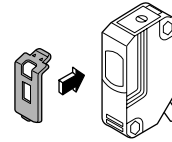

Interference prevention filter

(For NX5-M10R□ only)
Two sets of thru-beam type sensors (Red LED type) can be mounted closely.

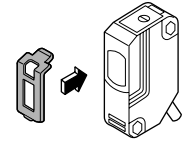

Reflector

- **RF-210**
- **RF-220**

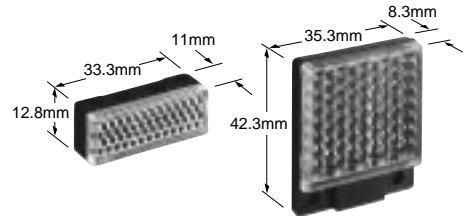

Reflective tape

- **RF-11**
- **RF-12**

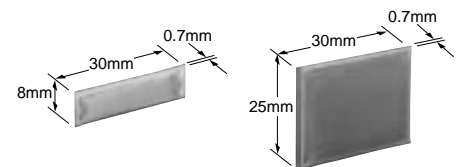

Sensor checker

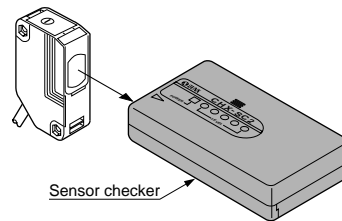

NX5

I/O CIRCUIT DIAGRAM

I/O circuit diagram

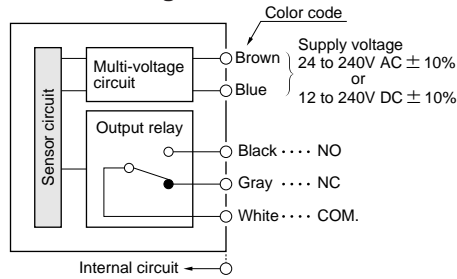

Note: The emitter of the thru-beam type sensor has two wires for power (+ V and 0V) only.

Output operation

■ : Object detected state.

Sensing mode	Thru-beam & Retroreflective type				Diffuse reflective type			
	Light-ON (A) type		Dark-ON (B) type		Light-ON (A) type		Dark-ON (B) type	
Output	NO (Black cable)	NC (Gray cable)	NO (Black cable)	NC (Gray cable)	NO (Black cable)	NC (Gray cable)	NO (Black cable)	NC (Gray cable)
Power OFF	Open	Close	Open	Close	Open	Close	Open	Close
Beam-received	Close	Open	Open	Close	Close	Open	Open	Close
Beam-interrupted	Open	Close	Close	Open	Open	Close	Close	Open

SENSING CHARACTERISTICS (TYPICAL)

All models

Correlation between setting distance and excess gain

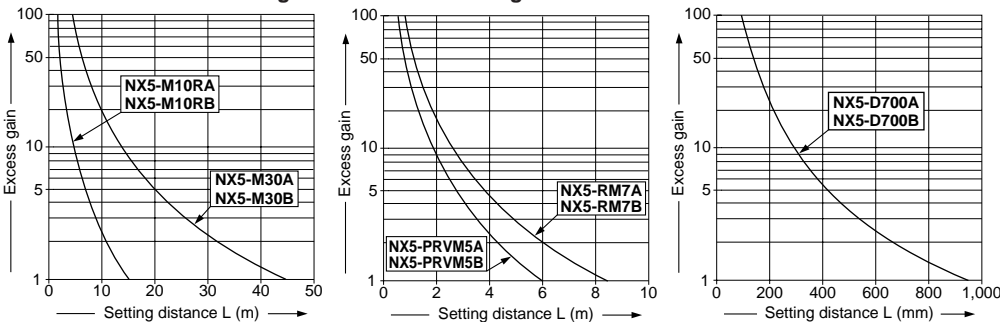

NX5-M10RA NX5-M10RB

Thru-beam type

Parallel deviation

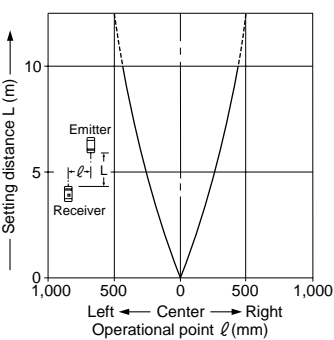

Angular deviation

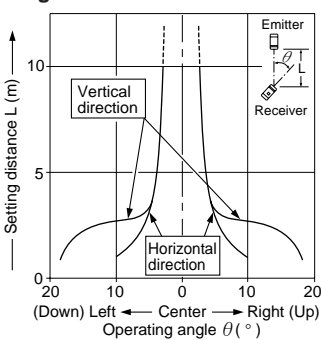

Parallel deviation with slit masks (3 x 6mm)

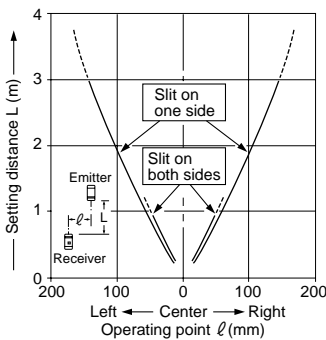

NX5-M30A NX5-M30B

Thru-beam type

Parallel deviation

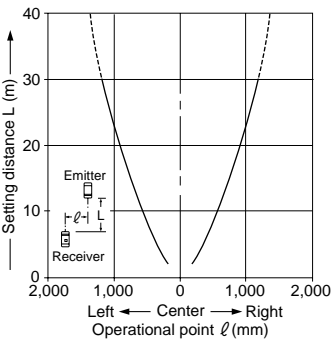

Angular deviation

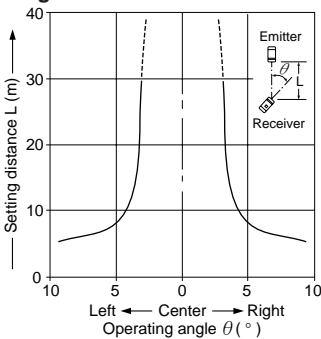

Parallel deviation with slit masks (3 x 6mm)

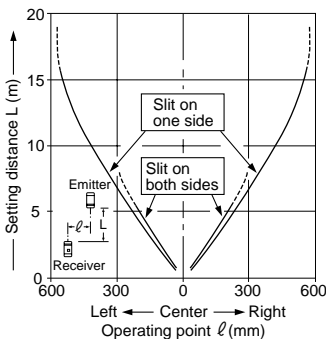

SENSING CHARACTERISTICS (TYPICAL)

**NX5-PRVM5A
NX5-PRVM5B**

Retroreflective type

Parallel deviation

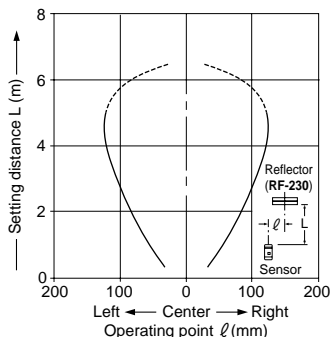

Angular deviation

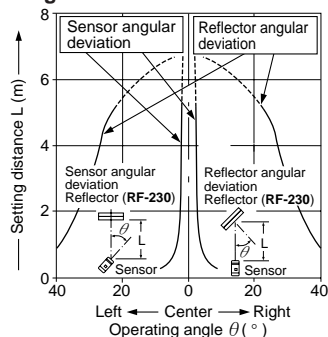

**NX5-RM7A
NX5-RM7B**

Retroreflective type

Parallel deviation

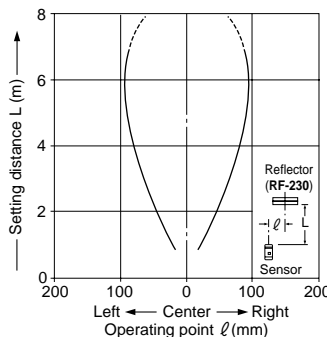

Angular deviation

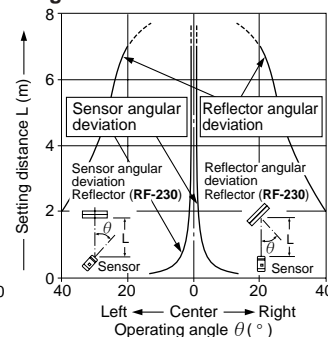

**NX5-D700A
NX5-D700B**

Diffuse reflective type

Sensing field

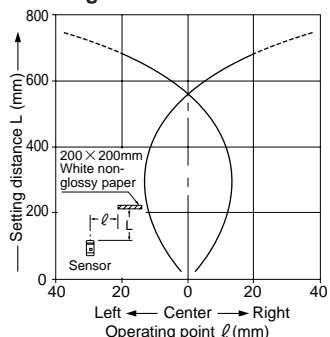

Correlation between sensing object size and sensing range

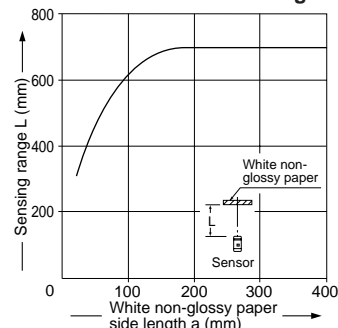

As the sensing object size becomes smaller than the standard size (white non-glossy paper 200 × 200mm), the sensing range shortens, as shown in the left graph.

(For plotting the left graph, the sensitivity has been set such that a 200 × 200mm white non-glossy paper is just detectable at a distance of 700mm.)

PRECAUTIONS FOR PROPER USE

Refer to P.820~ for general precautions.



This product is not a safety sensor. Its use is not intended or designed to protect life and prevent body injury or property damage from dangerous parts of machinery. It is a normal object detection sensor.

Mounting

- The tightening torque should be 0.8N·m or less.

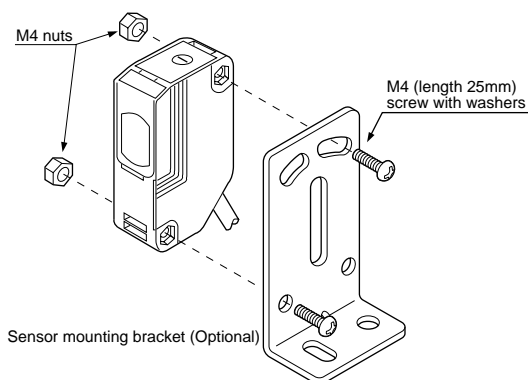

Interference prevention filter (Exclusively for NX5-M10R□)

- Use the interference prevention filters (optional) when two units of thru-beam type sensors are mounted closely.

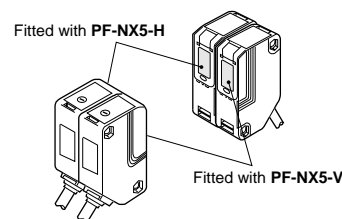

- There are two types of interference prevention filters. The two sets of thru-beam type sensors should be fitted with different types of interference prevention filters.

Note: The filters cannot be used for NX5-M30A or NX5-M30B.

Others

- Do not use during the initial transient time (50ms) after the power supply is switched on.

Sensor Mounting Stand
MS-AJ

Micro
PM

PM2

Multi-voltage Type
NX5
VF

Amplifier-separated Type
SU-7/SH

SS-A5

Sensor Checker
CHX-SC2

NX5

PRECAUTIONS FOR PROPER USE

Refer to P.820~ for general precautions.

Retroreflective type sensor (NX5-RM7□)

- Please take care of the following points when detecting materials having a gloss.

- ① Make L, shown in the diagram, sufficiently long.
- ② Install at an angle of 10 to 30 degrees to the sensing object.

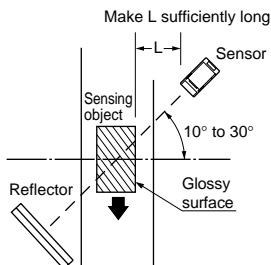

※ NX5-PRVM5□ does not need the above adjustment.

Retroreflective type sensor with polarizing filters (NX5-PRVM5□)

- If a shiny object is covered or wrapped with a transparent film, such as those described below, the retroreflective type sensor with polarizing filters may not be able to detect it.

In that case, follow the steps given below.

Example of sensing objects

- Can wrapped by clear film
- Aluminum sheet covered by plastic film
- Gold or silver color (glossy) label or wrapping paper

Steps

- Tilt the sensor with respect to the sensing object while fitting.
- Reduce the sensitivity.
- Increase the distance between the sensor and the sensing object.

DIMENSIONS (Unit: mm)

NX5-M10RA NX5-M30A
NX5-M10RB NX5-M30B

Sensor

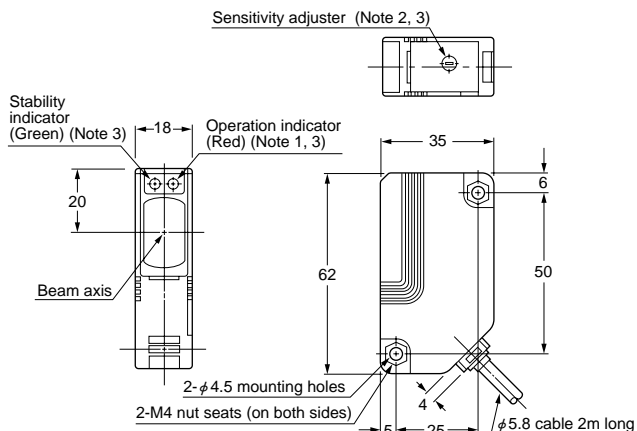

- Notes: 1) It is the power indicator on the emitter of NX5-M30□.
2) Not incorporated on NX5-M30□.
3) Not incorporated on the emitter.

NX5-PRVM5A NX5-RM7A
NX5-PRVM5B NX5-RM7B

Sensor

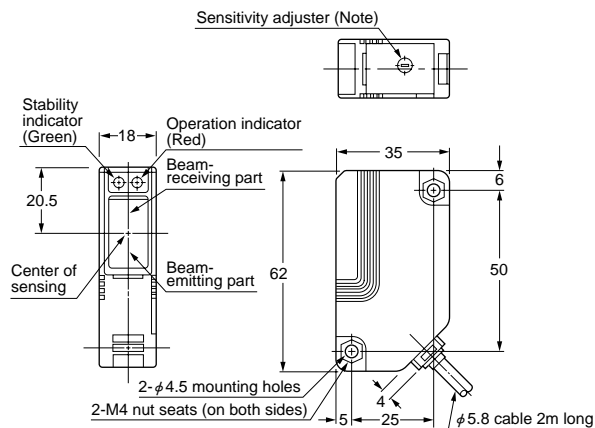

Note: Not incorporated on NX5-RM7□.

NX5-D700A
NX5-D700B

Sensor

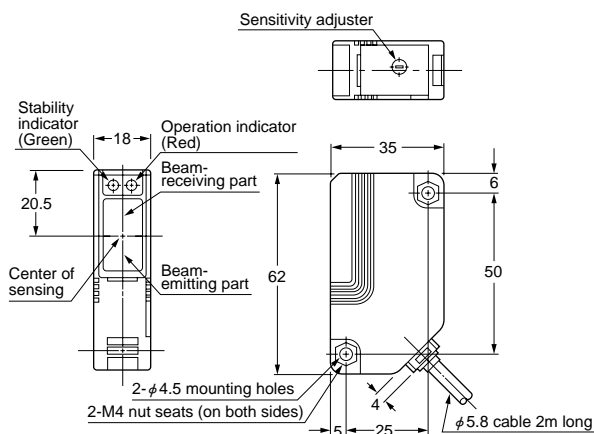

DIMENSIONS (Unit: mm)

RF-230

Reflector (Accessory for the retroreflective type sensor)

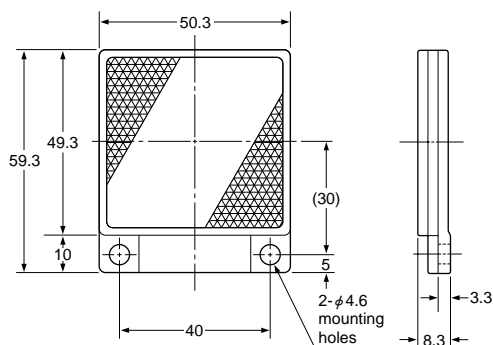

Material: Acrylic (Reflector)
ABS (Base)

RF-220

Reflector (Optional)

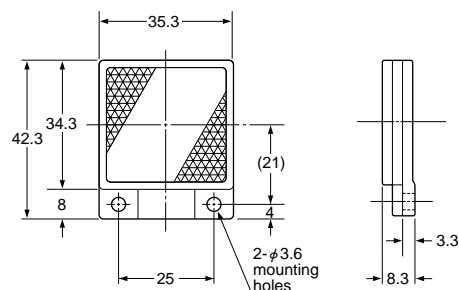

Material: Acrylic (Reflector)
ABS (Base)

RF-210

Reflector (Optional)

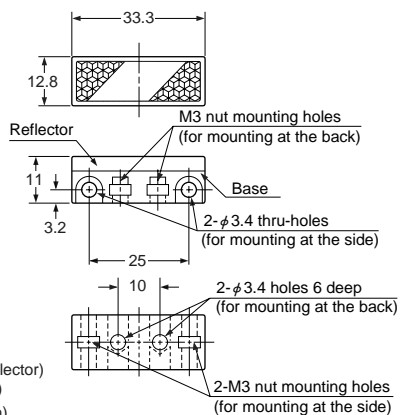

Material: Acrylic (Reflector)
ABS (Base)

Two M3 (length 8mm) screws with washers and two nuts are attached.

RF-11

Reflective tape (Optional)

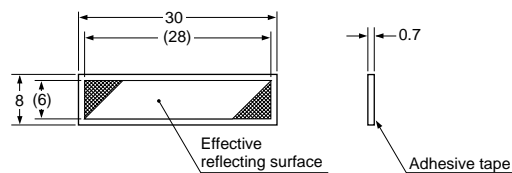

Material: Acrylic

RF-12

Reflective tape (Optional)

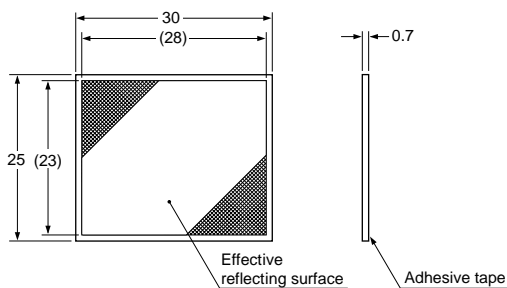

Material: Acrylic

Sensor Mounting Stand
MS-AJ

Micro
PM

PM2

Multi-voltage Type
NX5

VF

Amplifier-separated Type
SU-7/SH

SS-A5

Sensor Checker
CHX-SC2

NX5

DIMENSIONS (Unit: mm)

MS-NX5-1 Sensor mounting bracket (Optional)

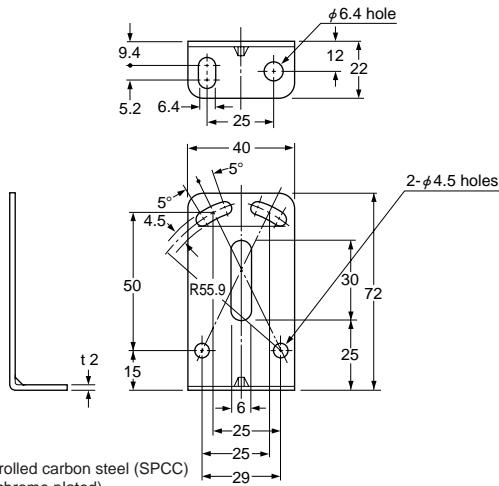

Material: Cold rolled carbon steel (SPCC)
(Uni-chrome plated)
Two M4 (length 25mm) screws with washers and
two M4 nuts are attached.

Assembly dimensions Mounting drawing with the receiver of NX5-M10R□

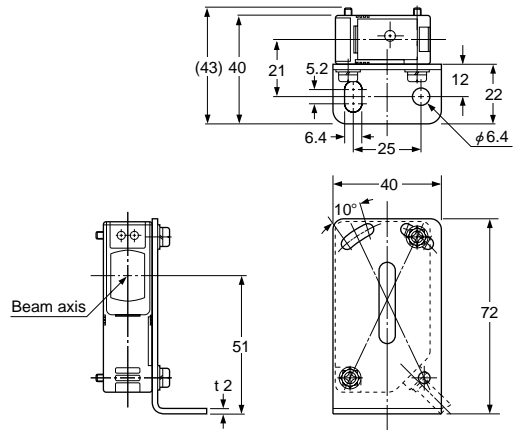

MS-NX5-2 Sensor mounting bracket (Optional)

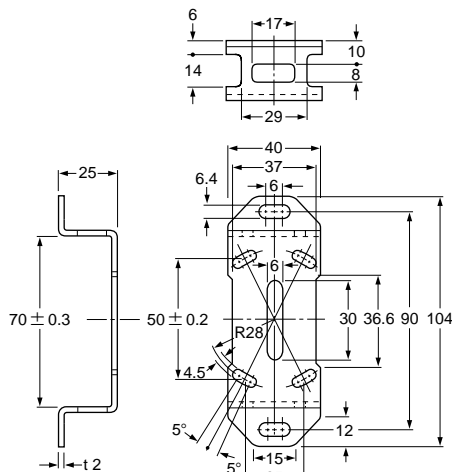

Material: Cold rolled carbon steel (SPCC)
(Uni-chrome plated)
Two M4 (length 25mm) screws with washers and
two M4 nuts are attached.

Assembly dimensions Mounting drawing with the receiver of NX5-M10R□

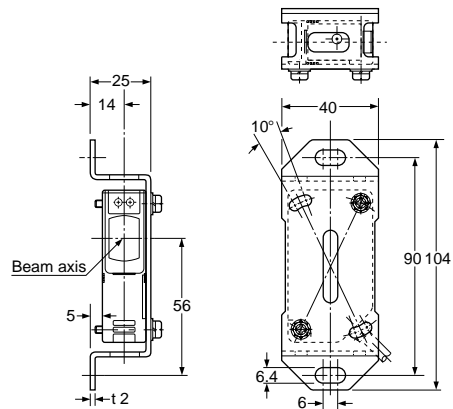

MS-NX5-3 Sensor mounting bracket (Optional)

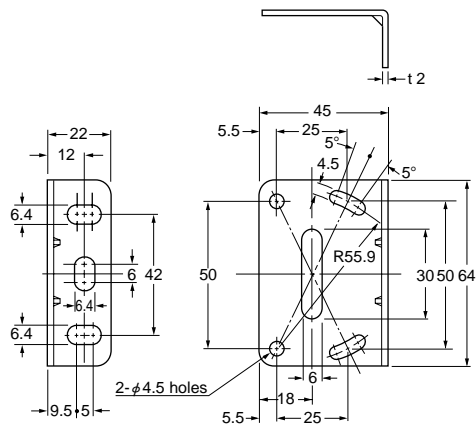

Material: Cold rolled carbon steel (SPCC)
(Uni-chrome plated)
Two M4 (length 25mm) screws with washers and
two M4 nuts are attached.

Assembly dimensions Mounting drawing with the receiver of NX5-M10R□

